

(No Model.)

2 Sheets—Sheet 1.

T. A. EDISON.
ALTERNATING CURRENT GENERATOR.

No. 470,928.

Patented Mar. 15, 1892.

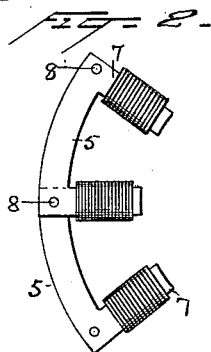
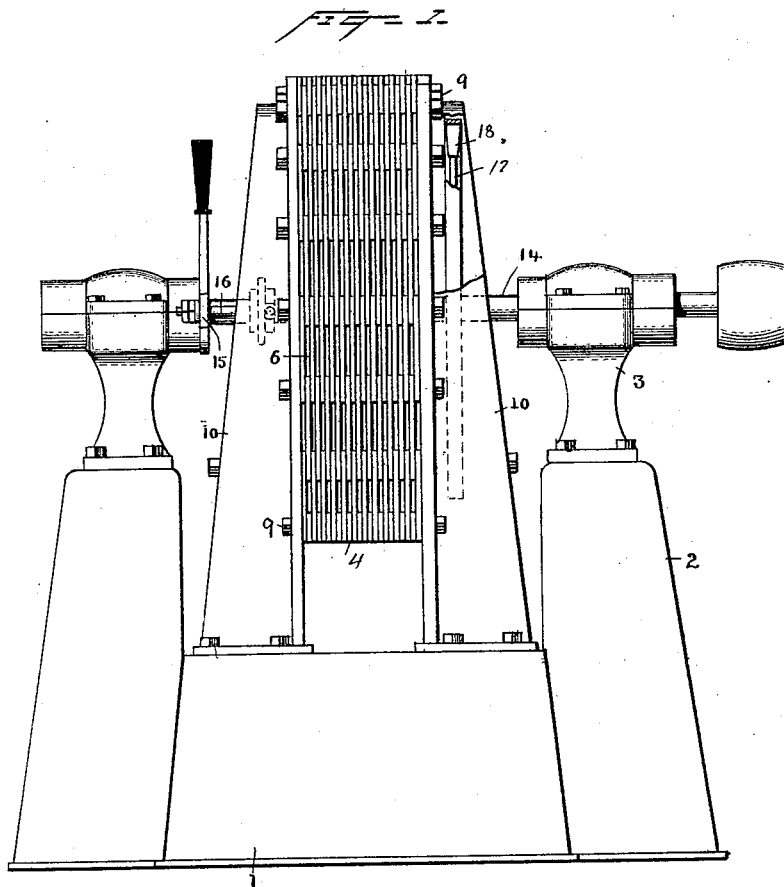

Witnesses
Morris A. Clark.
Eugene Douvan

Inventor
T. A. Edison,
By his Attorneys
Syert Seely.

(No Model.)

2 Sheets—Sheet 2.

T. A. EDISON.
ALTERNATING CURRENT GENERATOR.

No. 470,928.

Patented Mar. 15, 1892.

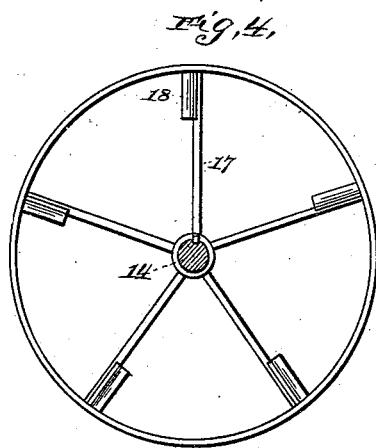
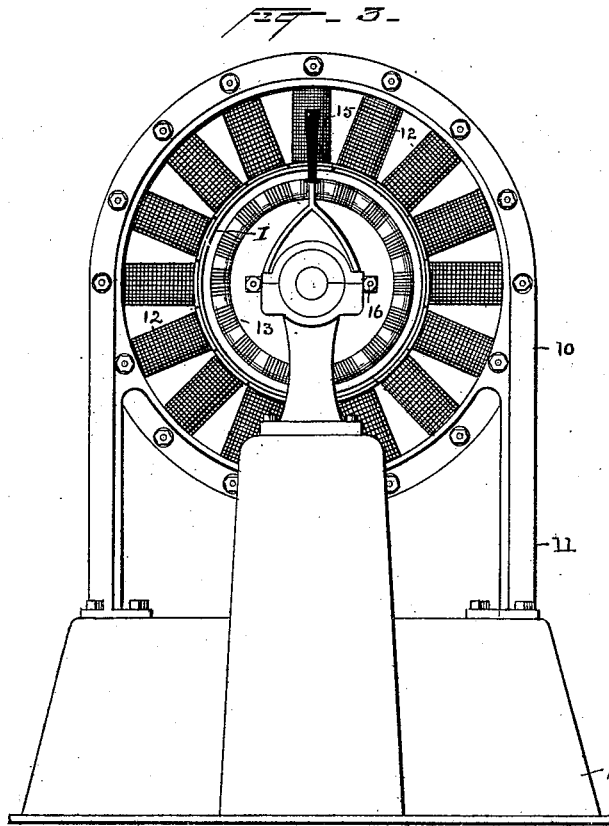

Witnesses
Irrnis A. Clark.
Eugene Bourau

Inventor
T. A. Edison,
By his Attorneys
Dyer & Selby.

UNITED STATES PATENT OFFICE.

THOMAS A. EDISON, OF LLEWELLYN PARK, NEW JERSEY.

ALTERNATING-CURRENT GENERATOR.

SPECIFICATION forming part of Letters Patent No. 470,928, dated March 15, 1892.

Application filed August 25, 1891. Serial No. 403,668. (No model.)

To all whom it may concern:

Be it known that I, THOMAS A. EDISON, a citizen of the United States, residing at Llewellyn Park, in the county of Essex and State of New Jersey, have invented a certain new and useful Improvement in Alternating-Current Generators, (Case No. 926), of which the following is a specification.

The present invention relates to dynamo-machines, and especially to such machines for generating alternating currents.

The main objects of the invention are to provide a simple and efficient construction of generators of this character by improving the construction of the field-magnet and of the frame of the machine and by certain features of construction, all of which will be hereinafter described.

In the accompanying drawings, Figure 1 is a side view of the generator. Fig. 2 is a detail view illustrating the construction of the field-magnet. Fig. 3 is a view at right angles to Fig. 1, looking from the left; and Fig. 4 shows the fan for cooling the armature.

The base 1 of the machine consists of a heavy casting having at each side standards 2, to which the journaled bearings 3 are bolted.

The field magnet 4 is circular and is built up in the following manner: A large number of magnetic plates 5, of substantially the form shown in Fig. 2, are arranged in parallel circles, the ends of the plates in one circle overlapping the ends of the plates in adjacent circles. The plates in any one circle do not meet end to end, but are separated by a considerable space, as indicated at 6 in Fig. 1. This makes the body of the field-magnet open, so that there is free circulation of air. The plates 5 are all of the same shape and may be formed by a single stamp or die. The plates have a main body, curved to conform to the general contour of the field-magnet, and projecting legs 7. These legs are shown at the ends of the plates. When, therefore, the plates are placed together in the position already described, the legs of the plates in the different circles rest directly against each other, so as to form laminated pole-pieces, the laminations of which are in direct surface contact. The plates are provided at the ends with bolt-holes 8, through which the bolts 9 are inserted for binding the plates together.

These bolts also pass through the end castings 10. The castings consist of ring-shaped bodies with supporting-legs 11, which are bolted to the base. On the pole-pieces which are integral with the body of the field-magnet, since they are formed by projecting legs 7, as described, the field-magnet coils 12 are wound so as to produce alternate + and - poles. Centrally within the field-magnet is mounted any suitable armature 13 on a shaft 14. The core of the armature is preferably composed of oxidized iron wire or of sheet-metal rings or plates. It is deemed unnecessary to describe in detail the construction and winding of the armature. The brushes are carried at the ends of the arm 15 by the rods 16 and bear on continuous rings, to which the terminals of the armature-wire are connected in a manner well understood.

In the thin annular space between the armature and magnet poles I place a strip of sheet-iron I, preferably joining the ends of the strip so as to form a closed ring or cylinder. This sheet-iron strip, plate, or ring is in direct contact with the poles of the magnet, and is held in place by the magnetism thereof without special fastening devices. When the armature rotates, this ring remains stationary, being mechanically independent of the armature. It is found that the use of this sheet-iron ring adds very materially to the efficiency of the generator. It also reduces the heating effect in the machine, due to Foucault currents. This reduction in the heating effect is probably due to the fact that the sheet-iron ring extends or spreads the fields to a certain extent on each side of the main bodies of the poles in such manner that the changes of polarity or alternation of current are more gradual than in machines where the poles are strong and confined to the centers of the field-magnet coils. Although the sheet-iron ring just described reduces the heat, it is still desirable to provide means for cooling the machine. For this purpose I provide a fan on the shaft 14. This fan consists of arms 17 carrying blades 18 so inclined that when they revolve with the shaft they will cause a circulation of air around the armature and magnet poles, and thus cools the same.

What I claim is—

1. In an electro-magnetic machine, the field-

magnet having several poles and consisting of overlapping magnetic plates bolted together so that the plates shall be in contact at the ends, but shall be separated throughout a portion of their length, said plates having main bodies and projecting legs, the latter constituting the field-magnet poles, substantially as described.

2. In an electro-magnetic machine, the field-magnet having several poles and consisting of overlapping magnetic plates bolted together so that the plates shall be in contact at the ends, but shall be separated throughout a portion of their length, said plates having main bodies and projecting legs, the latter constituting the field-magnet poles, and field-magnet coils on said poles, substantially as described.

3. In an electro-magnetic machine, a circular field-magnet built up of overlapping plates, said plates having bodies and projecting legs which constitute the pole-pieces of the field-magnet, and being in contact with each other for a portion only of their lengths, as set forth.

4. The combination, in an electro-magnetic machine, of a suitable base, two castings in the form of rings with supporting-legs mounted thereon, a field-magnet consisting of overlapping magnetic plates with projecting pole-pieces, and bolts passing through the castings

and through the overlapping ends of the plates, substantially as described.

5. The combination, with a field-magnet and an armature, of a sheet-iron plate resting against or adjacent to all the poles of the magnet, said plate being mechanically independent of the armature, substantially as described.

6. The combination, with a field-magnet and an armature, of a sheet-iron ring or cylinder directly between all of the field-magnet poles and the armature, and mechanically independent of the latter, substantially as described.

7. The combination, in an electro-magnetic machine, of a laminated open field-magnet with projecting poles, an armature revolving in front of said poles, and a fan for causing circulation of air, substantially as described.

8. The combination, in an electro-magnetic machine, of a field-magnet, a sheet-iron ring resting against the poles of said magnet, an armature within said ring, and a fan for causing circulation of air around the armature and field-magnet, substantially as described.

This specification signed and witnessed this 31st day of July, 1891.

THOS. A. EDISON.

Witnesses:

JOHN F. RANDOLPH.
FREDERICK OTT.