

(No Model.)

T. A. EDISON.
Brake for Electro-Magnetic Motors.

No. 228,617.

Patented June 8, 1880.

Fig. 1.

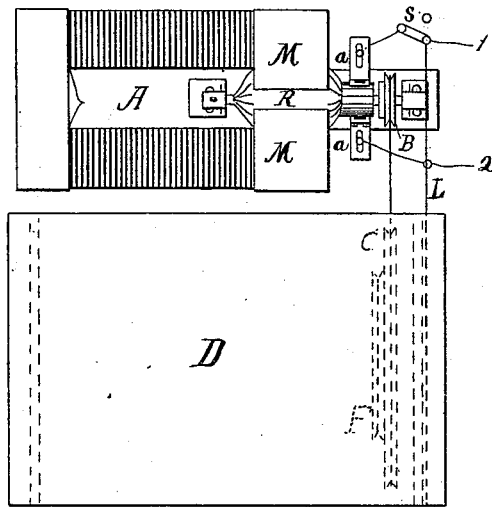

Fig. 2.

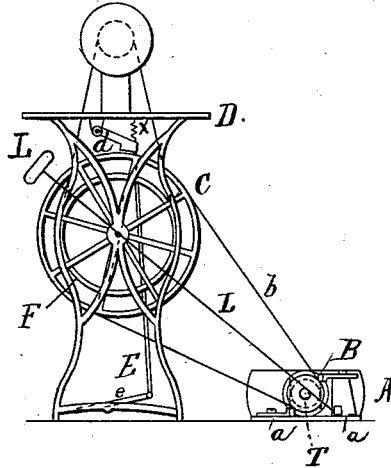
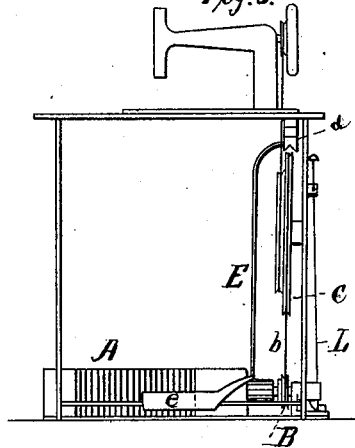

Fig. 3.



Attest:

Gaul. D. Mott
John C. Schroeder.

Inventor:

T. A. Edison
per Dyer & Miller
Attys

UNITED STATES PATENT OFFICE.

THOMAS A. EDISON, OF MENLO PARK, NEW JERSEY.

BRAKE FOR ELECTRO-MAGNETIC MOTORS.

SPECIFICATION forming part of Letters Patent No. 228,617, dated June 8, 1880.

Application filed March 20, 1880. (No model.)

To all whom it may concern:

Be it known that I, THOMAS A. EDISON, of Menlo Park, in the county of Middlesex and State of New Jersey, have invented a new and useful Improvement in Electro-Motors, (Case No. 207;) and I do hereby declare that the following is a full and exact description of the same, reference being had to the accompanying drawings, and to the letters of reference marked thereon.

In using electro-motors, especially for actuating light machinery, it is very desirable that the rate of speed of the actuated machine be under control of the operator, and that the means of control be simple, effectual, and easy of application. Hitherto this has been attempted only through controlling the electric circuit to the motor, breaking or closing it in whole or in part. This breaking of the circuit is destructive of the contact-points, and ordinarily effects only starting and stopping of the machine, and does not regulate the speed of the machine while running. I propose to control the speed of the driven machine without affecting the motor by the means more fully hereinafter described and claimed.

In the drawings, Figure 1 is a plan view of an electric motor and stand for a machine to be actuated thereby. Fig. 2 is an end view of the same, and Fig. 3 a front view.

A is any suitable electro-motor, in which R is the rotating armature, on whose shaft is a commutator, upon which press the springs or brushes *a a*, for completing the circuit from the conductors 1 2 to the motor.

Upon the shaft T is the pulley B, secured thereto by friction, the friction being so adjusted that the pulley and shaft shall be held and move together when only the resistance of the actuated machine is to be overcome, but that whenever a greater resistance is offered the friction shall be overcome and the shaft rotate within the pulley without rotating it.

From the pulley B a belt, *b*, leads to the large fly-pulley C, secured to the frame of the actuated machine. Upon the shaft of C is the pulley F, from which a belt transmits the motion to the actuated machine.

Upon the under side of the table D, or to any convenient part of the frame, is pivoted a brake, *d*, adapted to be brought to bear upon the pulley C, but held normally from so doing by a spring, *x*. To the brake *d* is pivoted the lever E, which passes down and is connected with a treadle, *e*, underneath the table. Through this treadle, then, any desired pressure may be put upon the periphery of the wheel C, regulating its speed, the current to the motor remaining unaffected and its rotation continued.

A switch, *s*, is used for breaking or closing the circuit to the motor. To the switch is attached a lever, L, which passes to the front of the machine, within easy reach of the operator. The current passes by wire 1 across the switch *s* when closed, as shown, through the motor, and out by wire 2, or vice versa. This switch may, if desired, be placed upon the frame or table of the actuated machine.

The form of brake used may be varied. For instance, it may be a belt-tightener, the belt *b* being normally loose, and the brake arranged to tighten it, so that it will take upon the pulleys and transmit motion from one to the other.

What I claim is—

1. The combination, with an electro-motor, of a mechanical brake, adapted to control the speed of the actuated machine, connected to the motor through a pulley fastened to the shaft of the motor by friction, substantially as set forth.

2. The combination, with an electro-motor, of a brake applied to the main driven wheel and controlling the speed of such wheel, but not that of the motor, substantially as set forth.

3. The combination, with an electro-motor, of a friction-pulley on the rotating shaft of the motor and a brake applied to the main driven wheel and adapted to control its speed, substantially as set forth.

This specification signed and witnessed this 10th day of March, 1880.

THOMAS A. EDISON.

Witnesses:

WM. CAERMAN,
C. P. MOTT.