

T. A. EDISON.  
TUBE SEALING MACHINE.  
APPLICATION FILED OCT. 14, 1905.

956,317.

Patented Apr. 26, 1910.

4 SHEETS—SHEET 1.

*Fig. 1.*

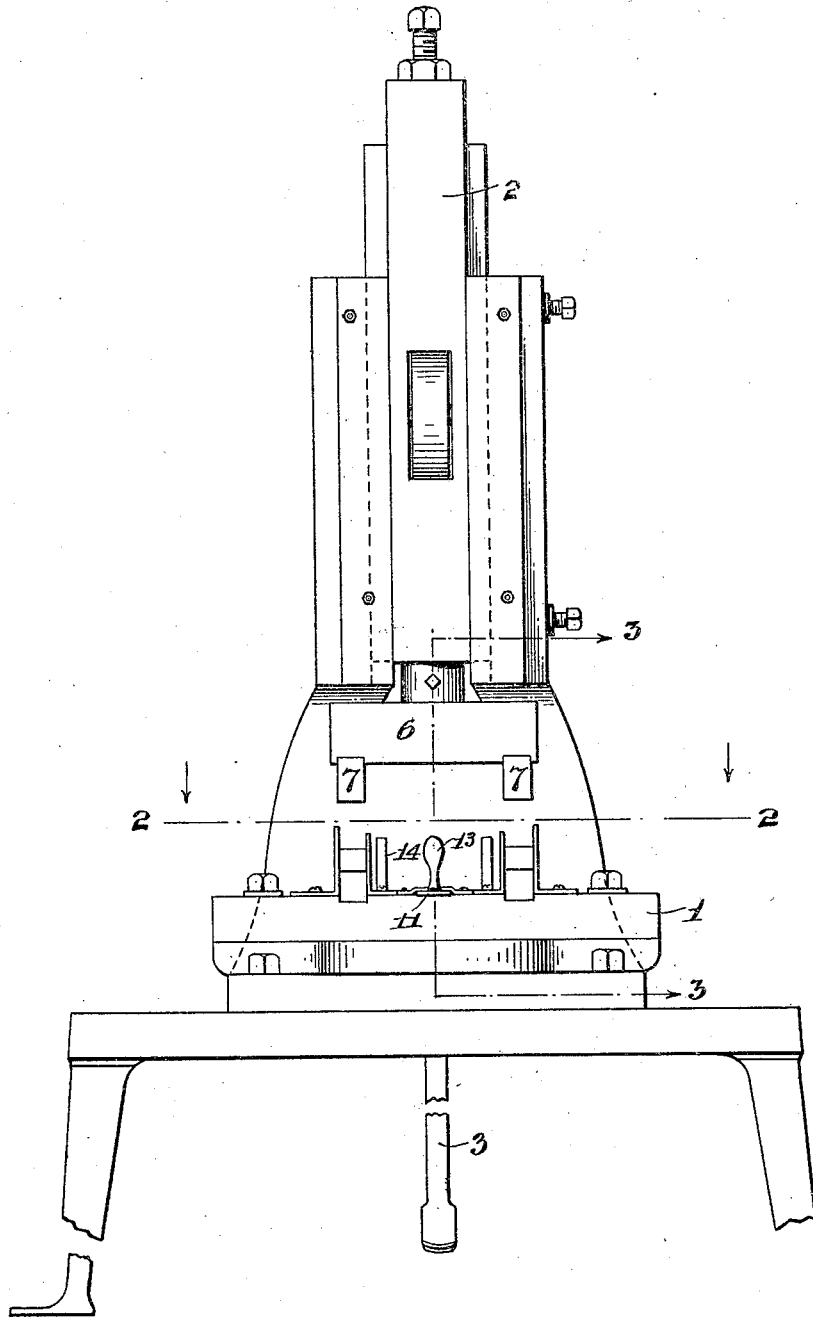

Attest:  
*Edgeworth*  
DeLos Stouden

Inventor:  
Thomas A. Edison  
by *Frank L. Raper* Atty.

T. A. EDISON.  
TUBE SEALING MACHINE.  
APPLICATION FILED OCT. 14, 1905.

956,317.

Patented Apr. 26, 1910.  
4 SHEETS—SHEET 2.

*Fig. 2.*

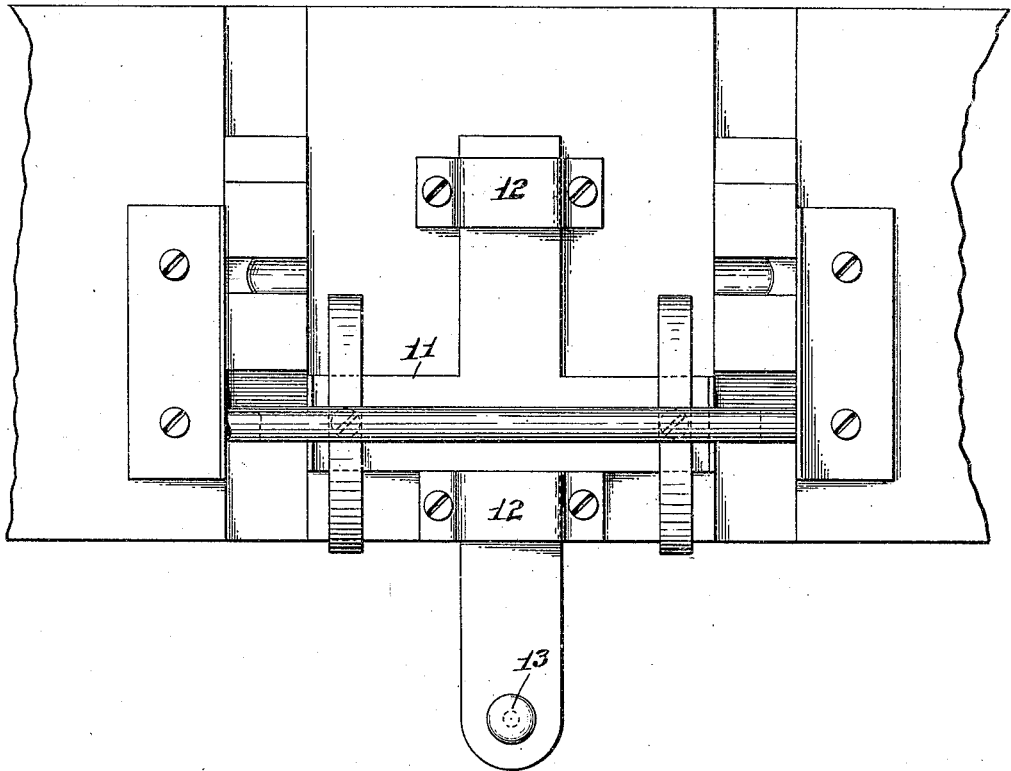

Attest:  
*Edgeworth*  
Delos Holden

Inventor:  
Thomas A. Edison  
by *O*  
Frank L. Spear Atty.

T. A. EDISON.  
TUBE SEALING MACHINE.  
APPLICATION FILED OCT. 14, 1905.

956,317.

Patented Apr. 26, 1910.

4 SHEETS—SHEET 3.

*Fig. 3.*

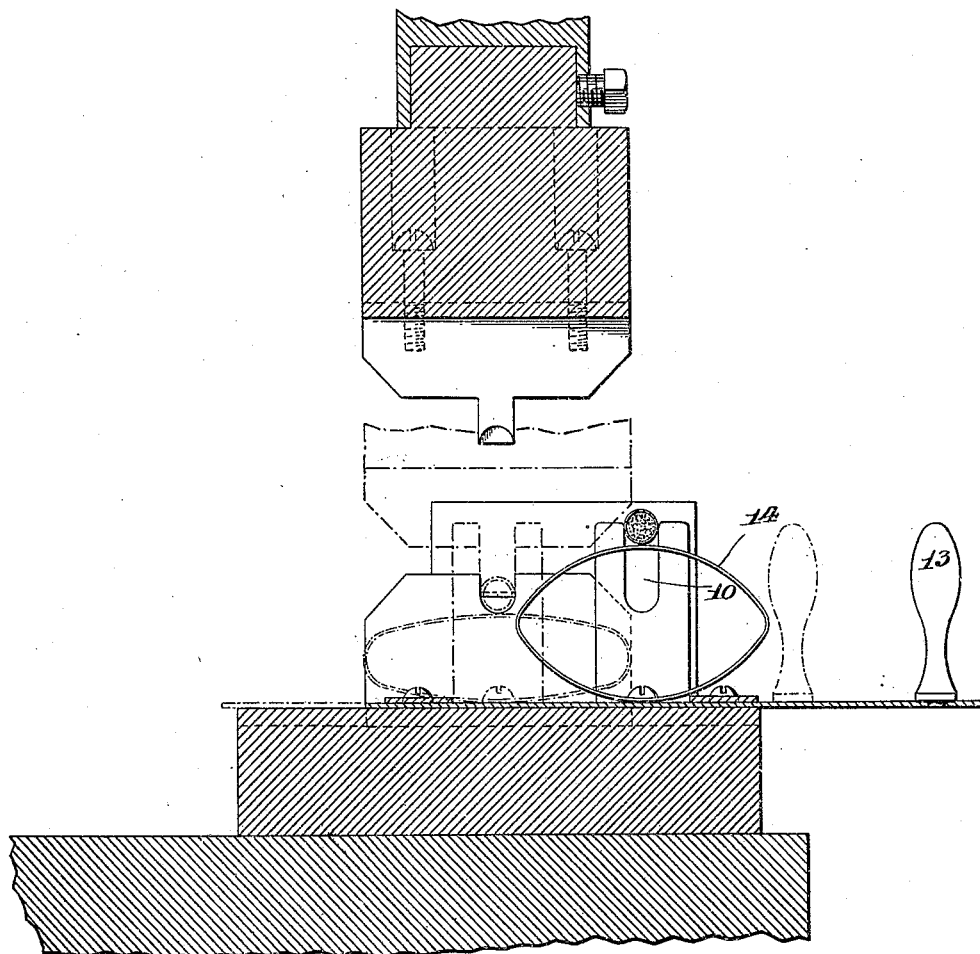

Attest:  
*Edgeworth*  
Delos Holden

Inventor:  
Thomas A. Edison  
by *O*  
Frank T. Spier Atty.

T. A. EDISON.  
TUBE SEALING MACHINE.  
APPLICATION FILED OCT, 14, 1905.

956,317.

Patented Apr. 26, 1910.

4 SHEETS—SHEET 4.

*Fig. 4.*

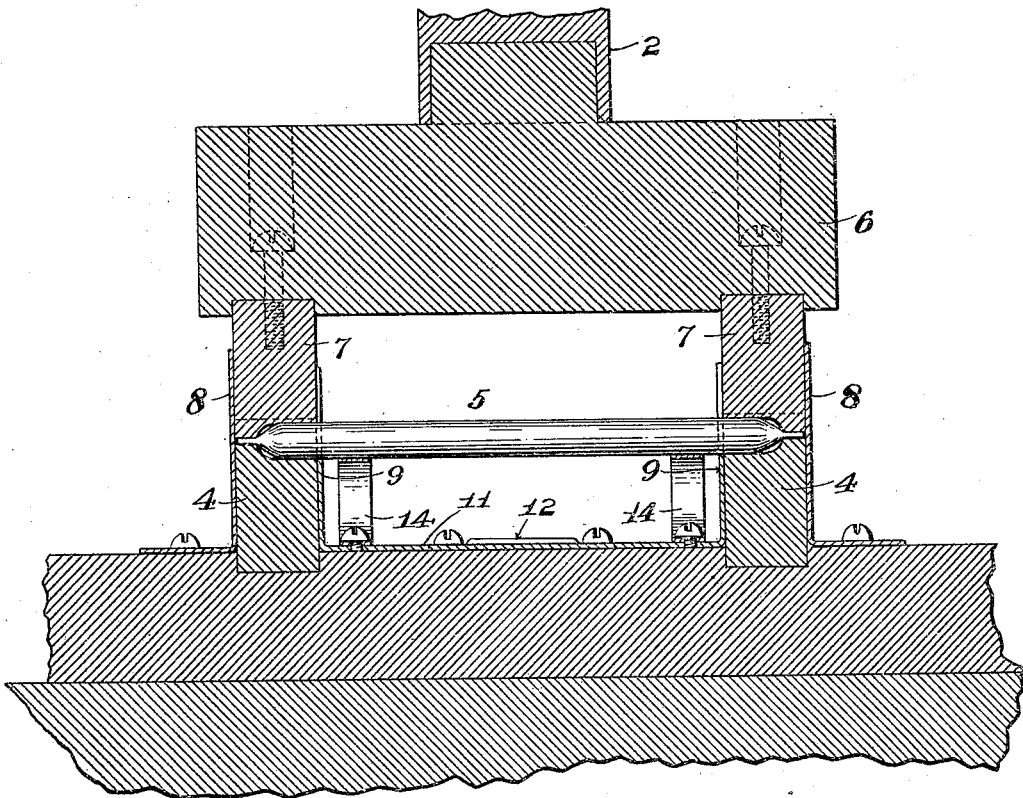

Attest:  
*Delos Holden*  
Delos Holden

Inventor:  
*Thomas A. Edison*  
by *Frank L. Spurr* Atty.

# UNITED STATES PATENT OFFICE.

THOMAS A. EDISON, OF ORANGE, NEW JERSEY.

TUBE-SEALING MACHINE.

956,317.

Specification of Letters Patent. Patented Apr. 26, 1910.

Application filed October 14, 1905. Serial No. 282,693.

To all whom it may concern:

Be it known that I, THOMAS ALVA EDISON, a citizen of the United States, residing at Llewellyn Park, Orange, in the county of Essex and State of New Jersey, have invented a certain new and useful Tube-Sealing Machine, of which the following is a description.

My invention relates to an improved machine, which has been designed particularly for sealing or compressing the ends of small tubes of thin perforated iron or steel, filled with active material and adapted to be assembled in a suitable support to constitute an electrode for storage batteries of the Edison type, as disclosed in an application filed by Thomas A. Edison and Jonas W. Aylsworth on April 28th, 1905, Serial No. 257,807.

My object is to provide a simple, convenient and efficient device for this purpose.

In order that the invention may be better understood, attention is directed to the accompanying drawings forming part of this specification, and in which—

Figure 1 is a front elevation of the machine in its preferred embodiment; Fig. 2, a plan view on an enlarged scale looking down from the line 2—2 of Fig. 1; Fig. 3, a section on the line 3—3 of Fig. 1; and, Fig. 4 a cross section through the compressing or sealing dies.

In all of these views, corresponding parts are represented by the same numerals of reference.

The main portion of the machine comprises a plunger press of any approved construction, having a bed 1 and a vertically moving plunger 2 operated from a foot lever 3 or in any suitable way. Mounted on the bed 1 are two dies 4—4 adapted to receive the tube 5, whose ends are to be compressed or sealed, which tube contains the active material in a highly compressed condition. The head 6 of the plunger 2 carries corresponding dies 7—7, which cooperate with the dies 4—4. Outside of the dies 4—4 are two alining plates 8—8 and within the said dies are two guide plates 9—9, having vertical slots 10 therein and forming a holder for guiding the tube into the dies 4—4. The guide plates 9—9 are carried by a sliding base 11, guided by sleeves 12 and provided with a handle 13. The base 11 is movable from the position shown in dotted lines to the position shown in full lines in

Fig. 3, whereby after the tube has been compressed or sealed, it may be moved forward away from the dies, so as to be readily removed by the operator. Two leaf springs 14 are mounted on the sliding base 11 and bear under the tube so as to elevate the same from the dies 4 when the pressure of the dies 7 is removed, as will be understood. The compressed and expanded position occupied by the springs 14 are shown in dotted and full lines, respectively, in Fig. 3.

In operation, one of the tubes is placed on the springs 14 in the upper part of the slots 10, being alined by the plates 8—8 (see full lines, Fig. 3) after which the handle 13 is moved inward to bring the tube into line with the dies 4—4. The plungers are now operated and cause the dies 7 to compress the ends of the tubes tightly together, resulting in the sealing of the material therein.

Having now described my invention, what I claim as new therein and desire to secure by Letters Patent is as follows:

1. In a tube sealing machine, the combination of cooperating dies for laterally compressing simultaneously both ends of tubes for sealing the same, a horizontally movable sliding holder for carrying a tube and laterally directing the same into position between said dies, and means for operating said dies to laterally compress said tube ends and thereby seal the same, substantially as set forth.

2. In a tube sealing machine, the combination of cooperating dies for compressing simultaneously the ends of a tube, and springs for removing the tube from the dies after the sealing pressure has been applied, substantially as set forth.

3. In tube sealing machines, the combination with a pair of stationary dies and a pair of movable dies, of a sliding frame for holding a tube and guiding the same laterally into position between said dies, with said stationary dies disposed to one side of the ends of said tube, and said movable dies disposed opposite the same on the other side of said ends of said tube, substantially as set forth.

4. In tube sealing machines, the combination with a pair of stationary dies, and a pair of movable dies, of a sliding frame for holding the tubes and guiding the same into position between said dies, and springs carried by said sliding frame for elevating the

sealed tubes from the stationary die after the sealing pressure has been applied, substantially as set forth.

5     5. In a tube sealing machine, the combination with stationary and movable dies, of a sliding member for holding a tube and guiding the same laterally into position between said dies with said stationary dies disposed to one side of the ends of said tube,  
10 and said movable dies disposed opposite the same on the other side of said ends of said tube, substantially as set forth.

6. In a tube sealing machine, the combina-

tion with cooperating dies for sealing simultaneously both ends of tubes by lateral compression thereon, of means for feeding the tubes into position to be acted upon by the dies, and means for removing the tubes from the dies, substantially as set forth. 15

This specification signed and witnessed this 12th day of October 1905. 20

THOS. A. EDISON.

Witnesses:

FRANK L. DYER,

MINA C. MAC ARTHUR.